

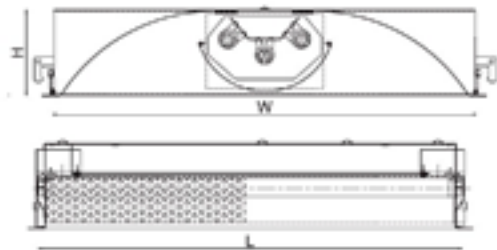

Dimensions



Size	L (Inches)	W (Inches)	H (Inches)
2'x2'	23,74	23,74	4,76
2'x4'	47,71	23,74	4,76

Features & Benefits

- Recessed Mounted.
- Electrostatically applied polyester powder coat paint in Matte White Finish with 92% reflectance.
- Formed and welded in 23 Gauge steel (0,60mm).
- Easy removal of diffuser, without any tools.
- Perforated diffuser, with 60% open area.

Packing

Size	Light Emission	Unit Weigh (Pounds)	Qty/ Pallet	Pallet's/ 40'Cnt	Weigh per Pallet (Pounds)
2'x2'	Lamp LED	9,90	160	23	1584
2'x4'	Lamp LED	16,83	100	22	1683

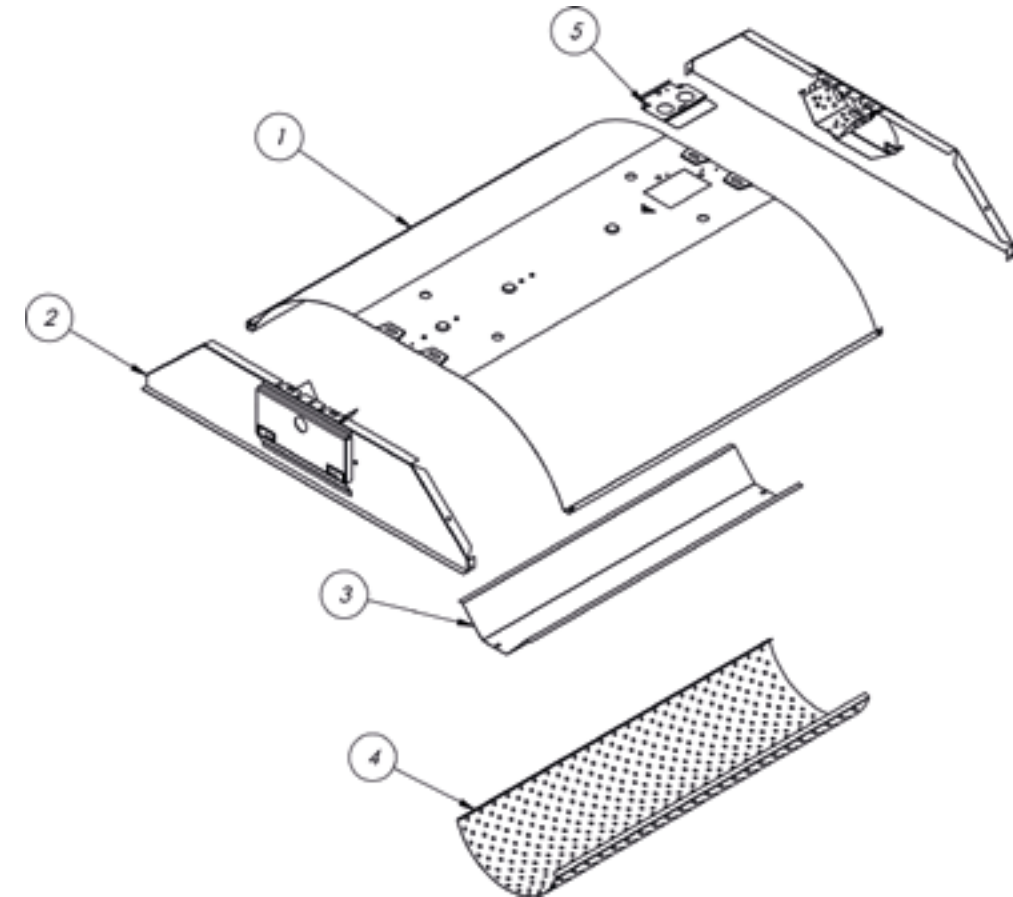

DTS 2517 2x2			DTS 2517 2x4		
DESCRIPTION	PART NUMBER	QTTY	DESCRIPTION	PART NUMBER	QTTY
Body	2517 2210	1	Body	2517 2410	1
Headboard	2517 2231	2	Headboard	2517 2231	2
Ballast Cover	2517 2261	1	Ballast Cover	2517 2461	1
Perforated Diffuser	1517 2282	1	Perforated Diffuser	1517 2482	1
Acess Plate	510 15	1	Acess Plate	510 15	1

*Lens are optional, available to purchase separately.
*Metal Parts Only, Hardware necessary to assemble are not included.