

Backlight

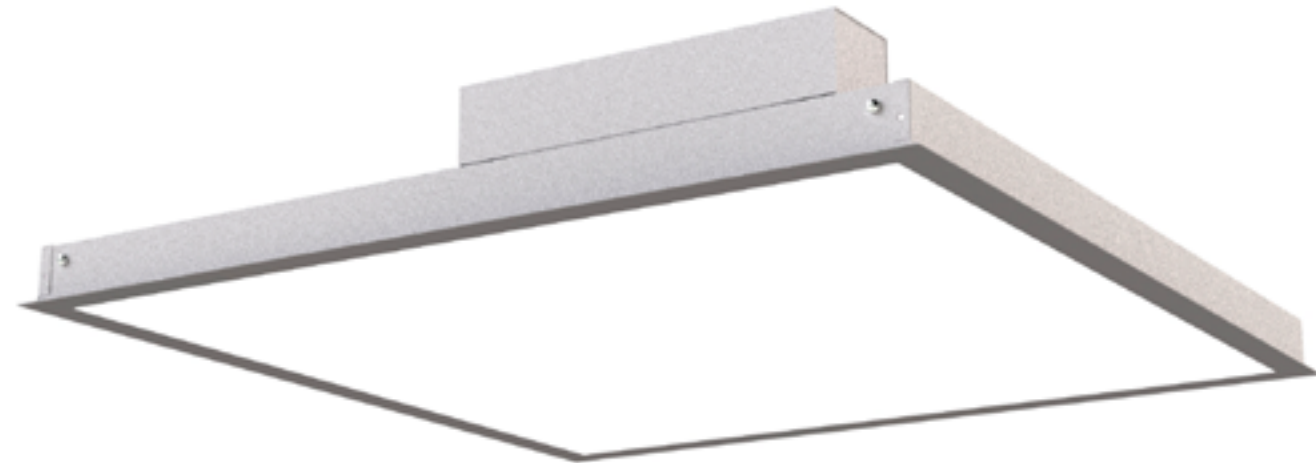

Dimensions

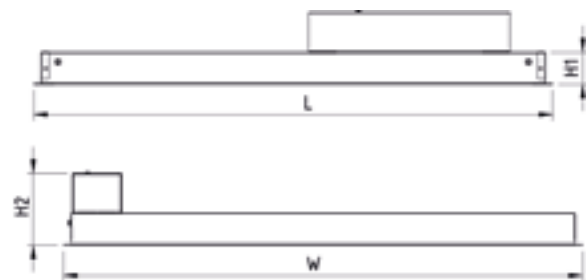

Size	L (Inches)	W (Inches)	H (Inches)	H2
2'x2'	23,74	23,74	1,46	3,46

Features & Benefits

- Recessed Mounted.
- Electrostatically applied polyester powder coat paint in Matte White Finish with 92%.
- Driver Box System for Driver installation.
- Formed and welded in 26 Gauge steel (0.45mm). Driver Box system in 23 gauge steel (0.60mm).
- Flat Sheet Diffuser with 80% light transmission.

Packing

Size	Light Emission	Unit Weigh (Pounds)	Qty/ Pallet	Pallet's/ 40'Cnt	Weigh per Pallet (Pounds)
2'x2'	Led Modules	6,05	250	27	1331

Backlight

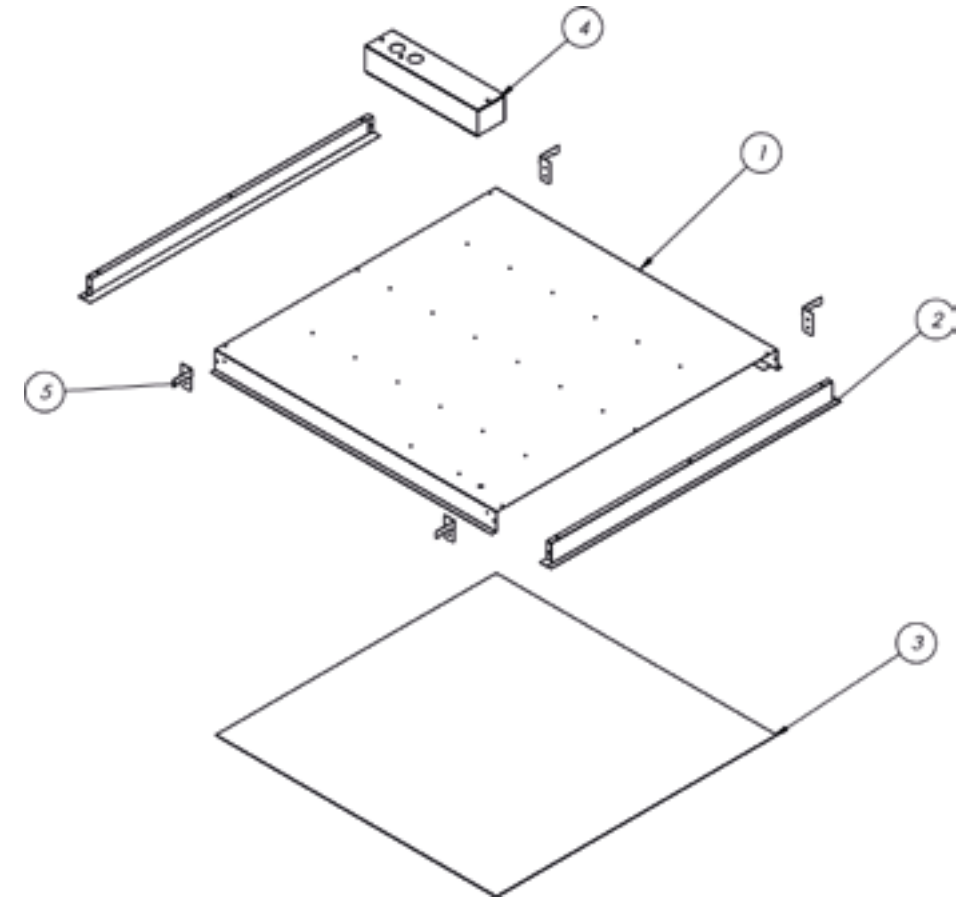

Backlight 2x2		
DESCRIPTION	PART NUMBER	QTTY
Body	BKL 2210	1
Headboard	BKL 2231	2
Plastic Lens	BKL 2252	1
Driver Cover	BKL 2261	1
Earthquake Protection	02	4

*Lens are optional, available to purchase separately.
*Metal Parts Only, Hardware necessary to assemble are not included.

